

THIS DRAWING IS UNPUBLISHED.

RELEASED FOR PUBLICATION

ALL RIGHTS RESERVED.

© COPYRIGHT - By -

LOC AF DIST 50

REVISIONS

P	LTR	DESCRIPTION	DATE	DWN	APVD
	AL	REVISED PER ECR-12-013445	09NOV12	KH	PD

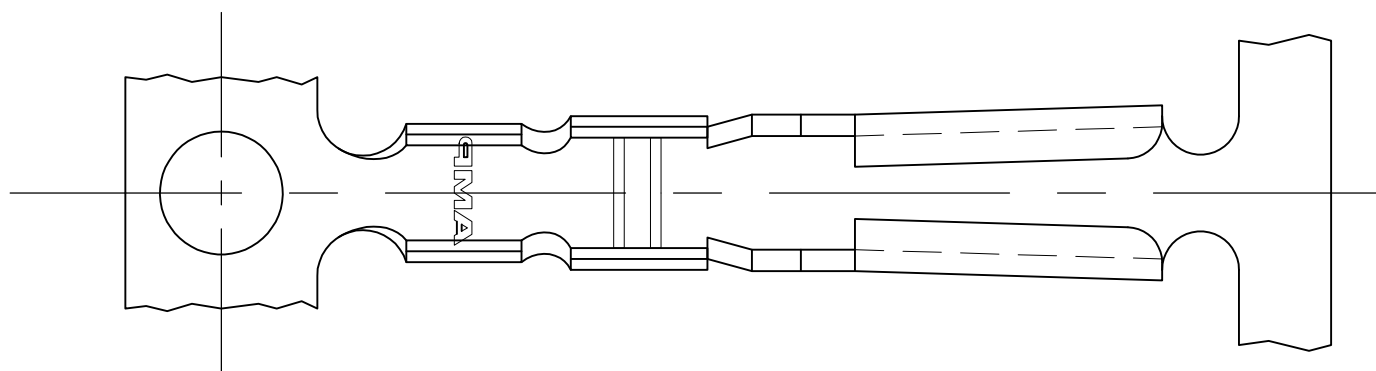

- 1 CONTINUOUS STRIP ON REELS.
- 2 WIRE SIZE IS [#24-#22] AWG.
- 3 INSULATION RANGE IS 1.52 [.060]MAX
- 4 ACCEPTS 0.58-0.41 [.023-.016] THK TAB.
- 5 SAME AS 41355 EXCEPT REVERSE REEL FOR ARTOS MACHINE.

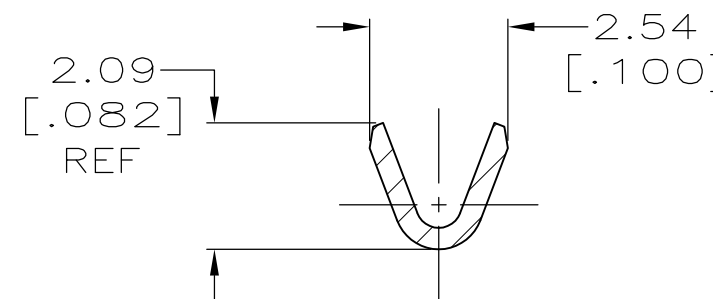
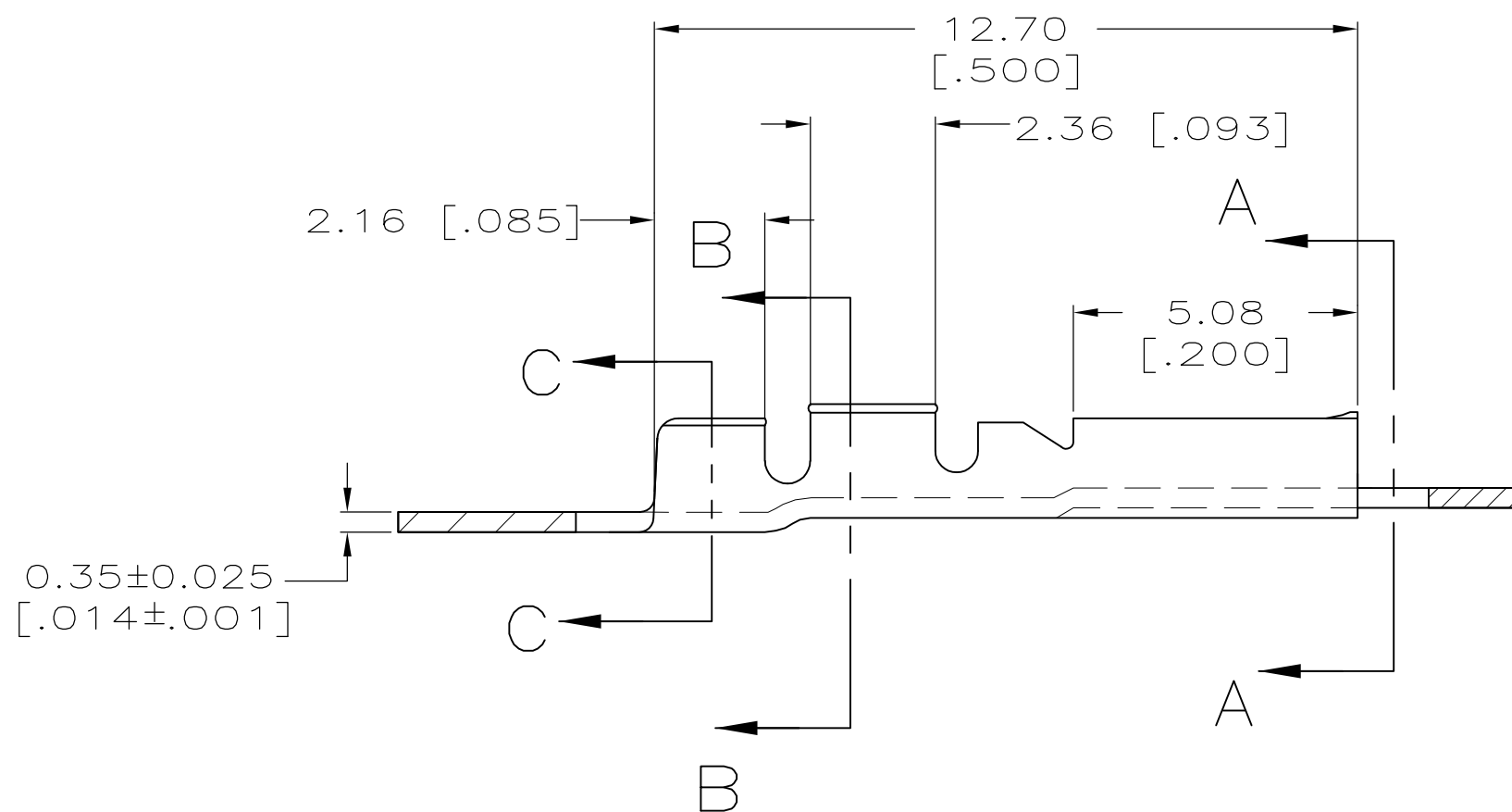

SECTION B-B

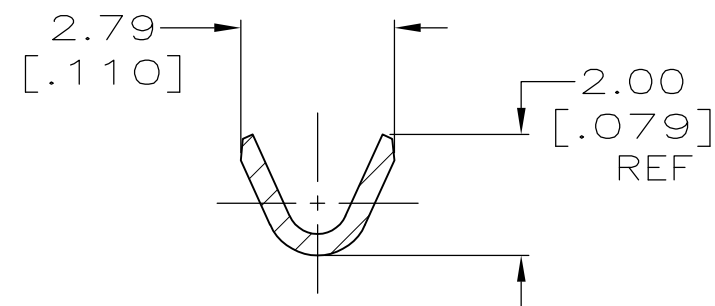

SECTION C-C

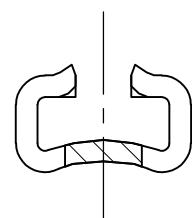

SECTION A-A

42765-1
PART NO.

THIS DRAWING IS A CONTROLLED DOCUMENT.		DWN JR RUTH 12OCT99	STE TE Connectivity		
DIMENSIONS: mm [INCHES]		CHK S HEADER 12OCT99			
TOLERANCES UNLESS OTHERWISE SPECIFIED:		APVD S HEADER 12OCT99	NAME RECEPTACLE, TAPER TAB, 2.0 [.078] SERIES		
0 PLC ± -	1 PLC ± -	PRODUCT SPEC	SIZE A3 CAGE CODE 00779 DRAWING NO C-42765 RESTRICTED TO -		
2 PLC ± 0.38 [.015]	3 PLC ± -	APPLICATION SPEC	SCALE 8:1 SHEET 1 OF 1 REV AL		
4 PLC ± -	ANGLES ± -	WEIGHT -	CUSTOMER DRAWING		
MATERIAL BRASS		FINISH 0.002032 [.000080] MIN TIN			